

*Silver Cross*<sup>®</sup>

# DUNE

**Chassis & Seat  
Instruction Manual**

**IMPORTANT - READ THE INSTRUCTIONS CAREFULLY BEFORE USE AND KEEP FOR FUTURE REFERENCE**

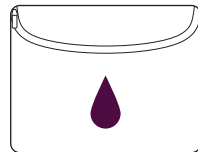
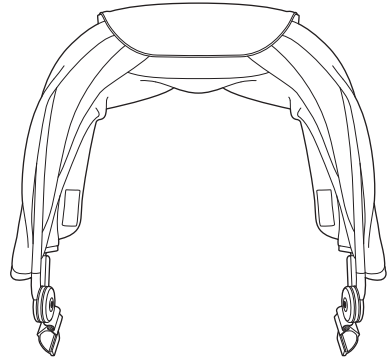
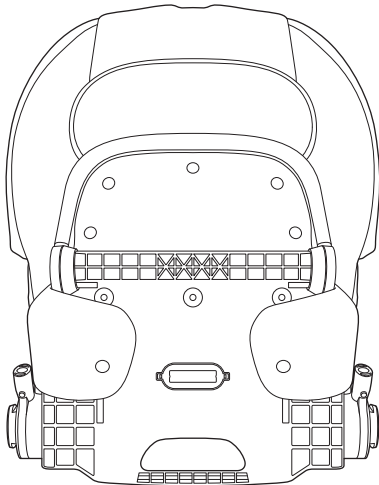
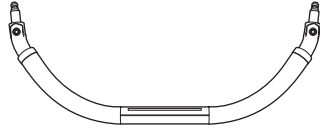
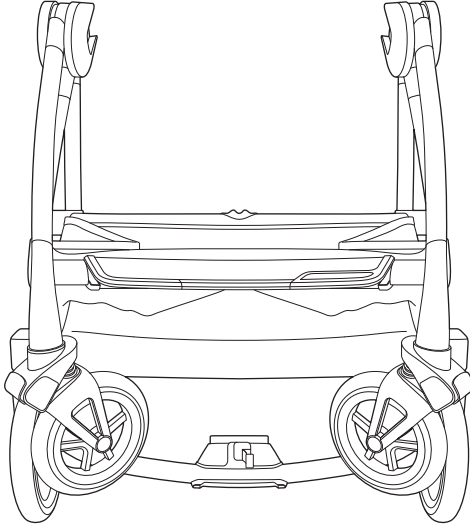

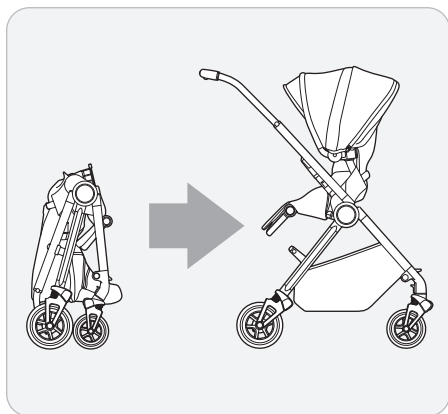

1.1

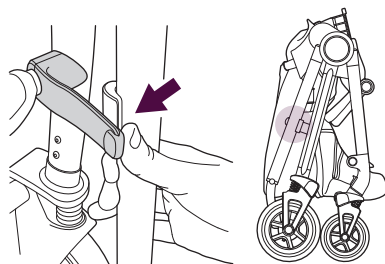

1.2

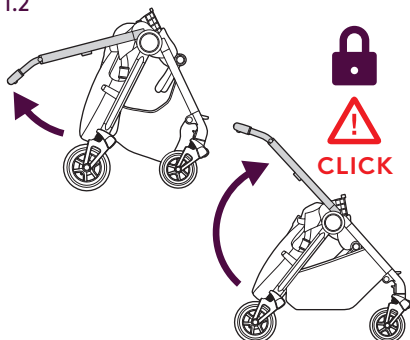

1.3

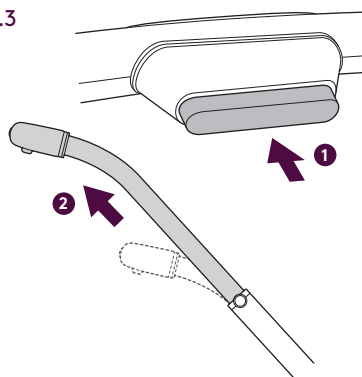

1.4

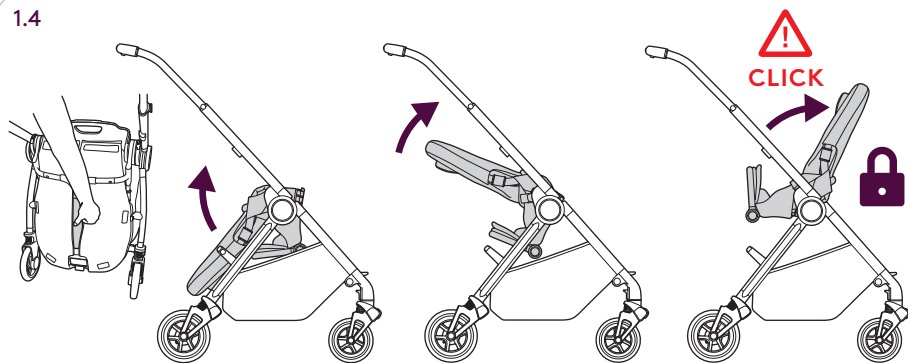

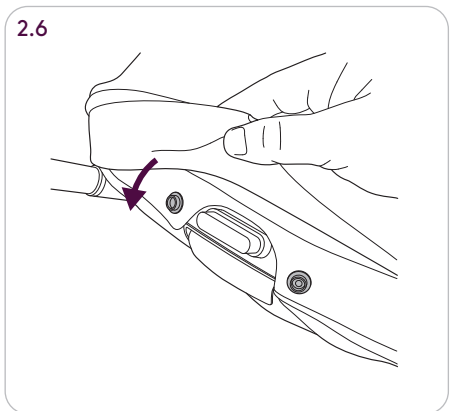
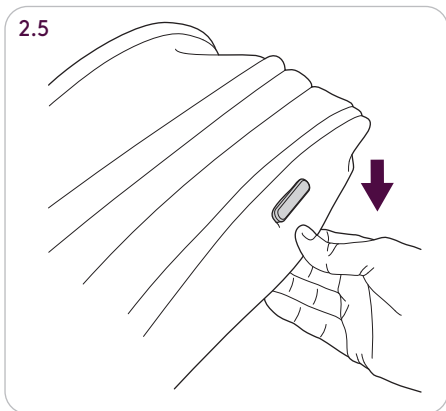
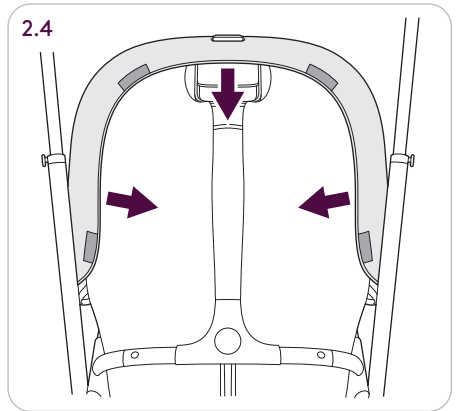
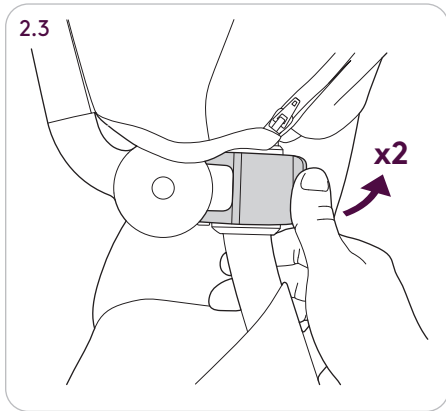
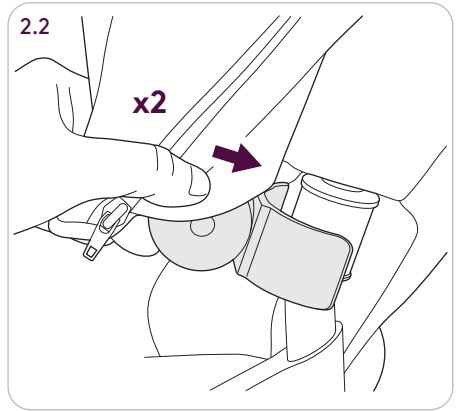
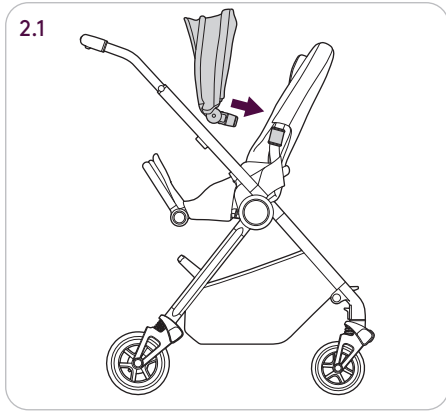

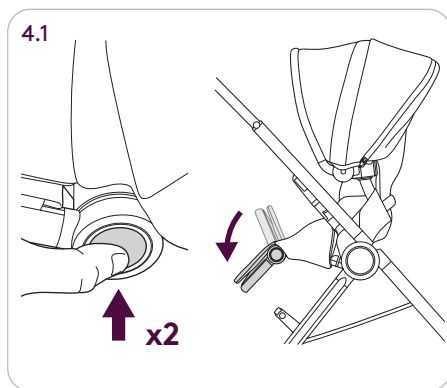
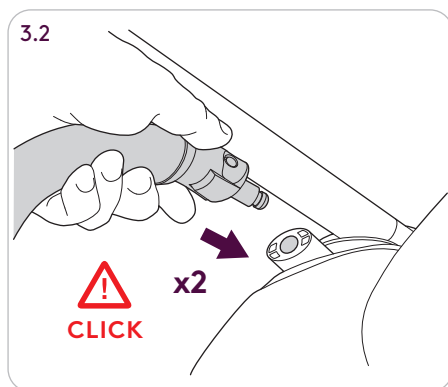
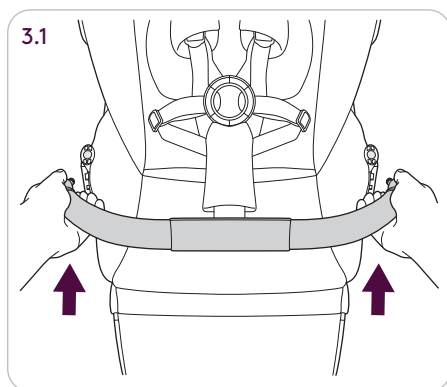
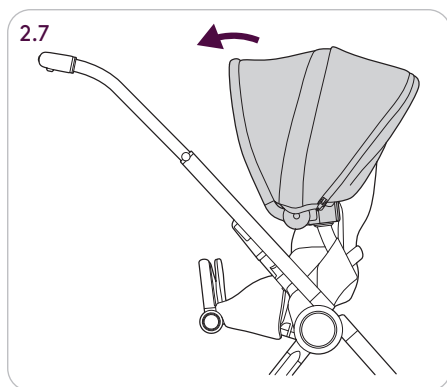

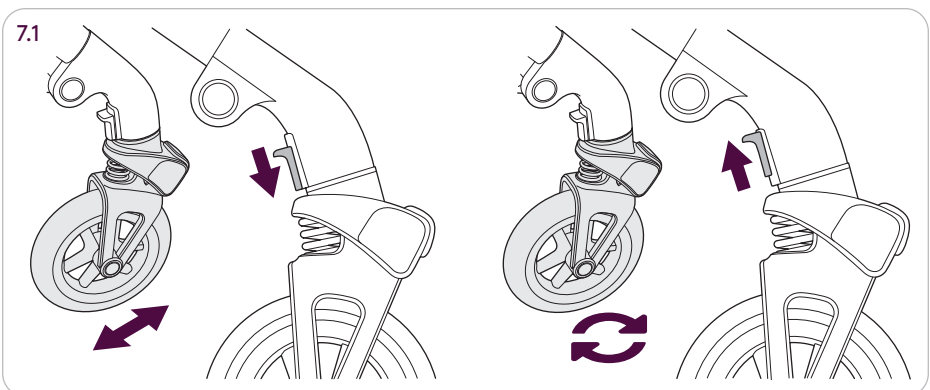
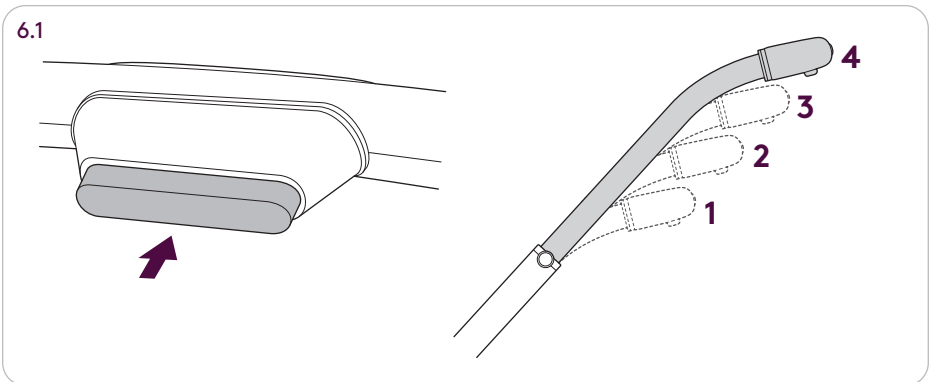
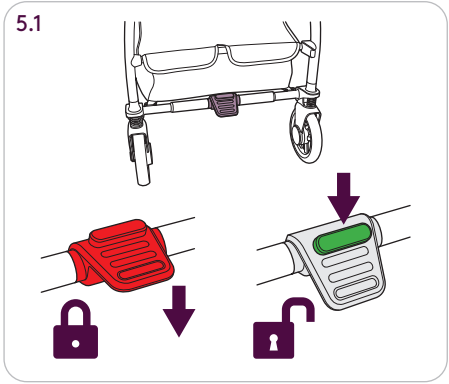
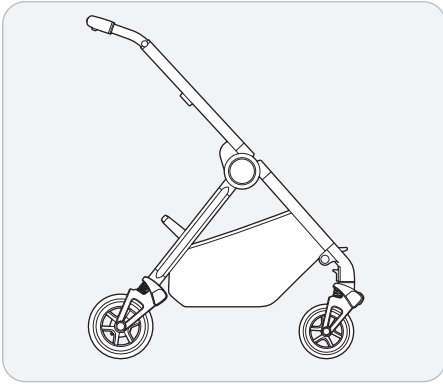

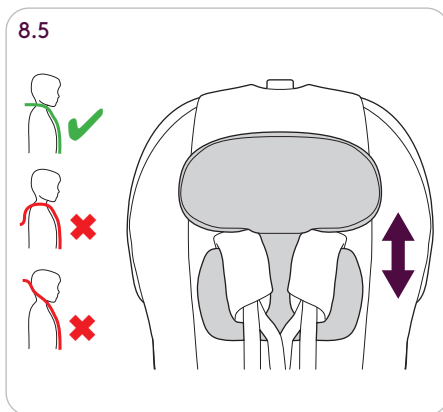
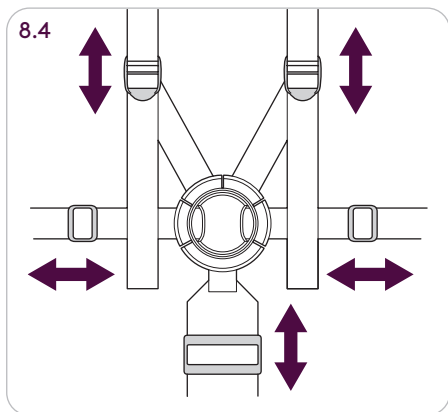
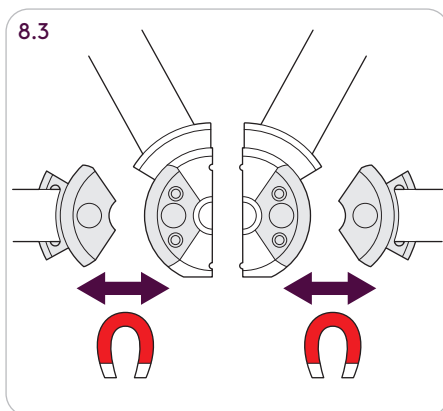
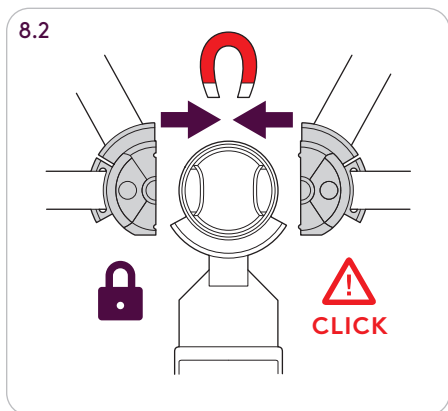
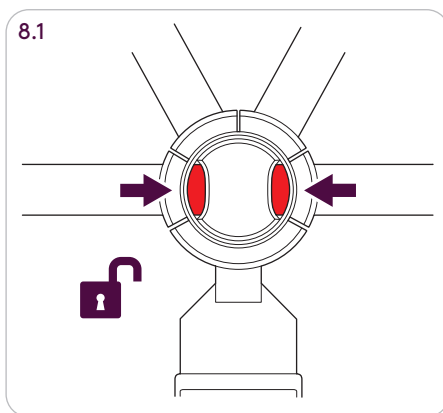
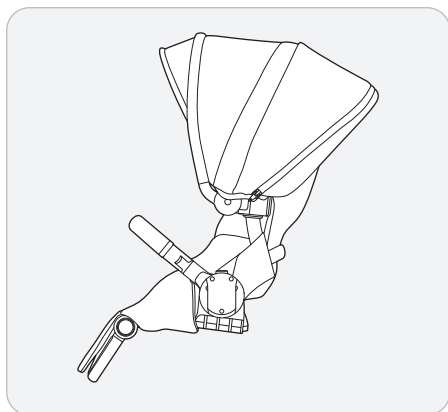

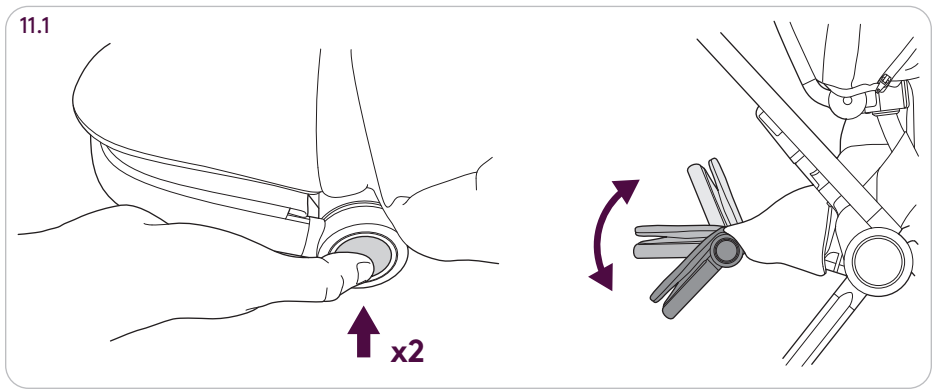
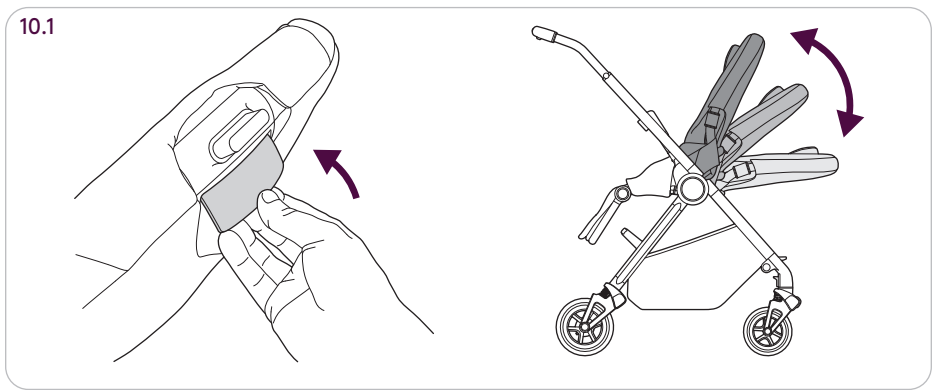
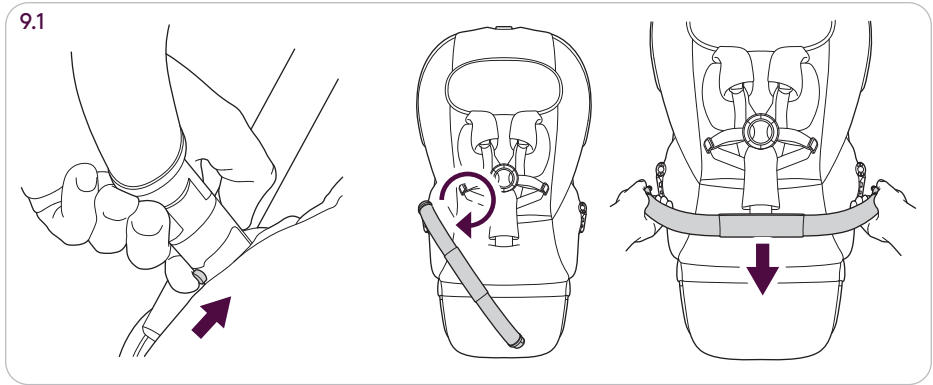



12.1

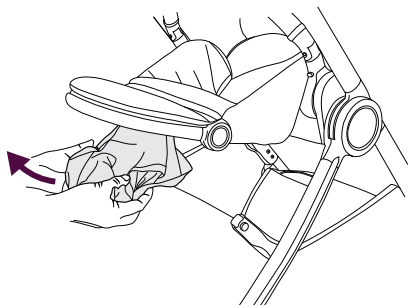

12.2

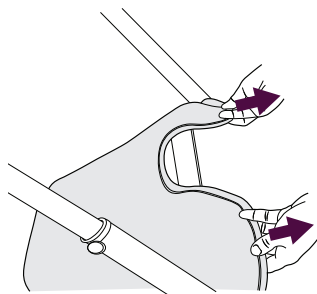

12.3

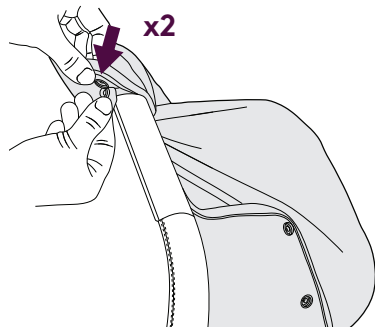

13.1

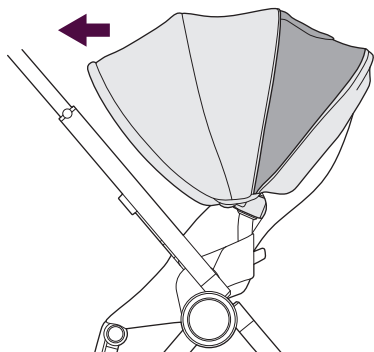
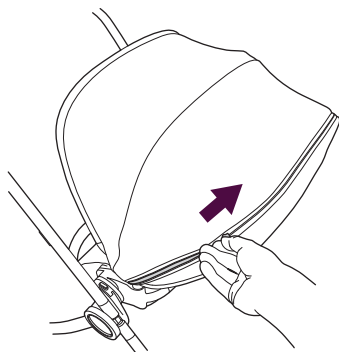

14.1

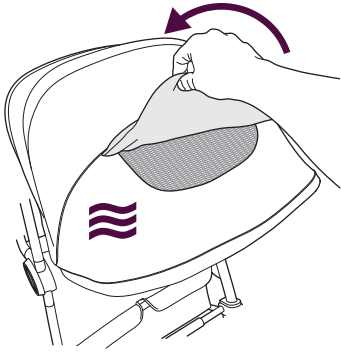

14.2

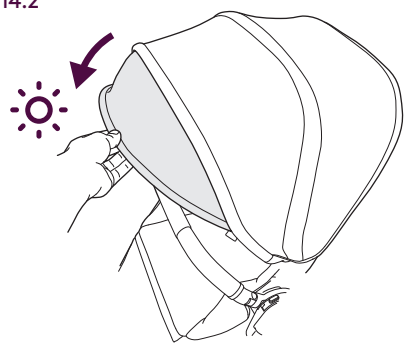

15.1

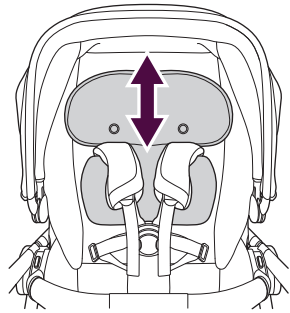
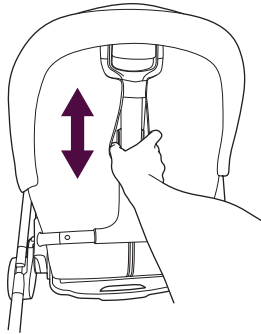
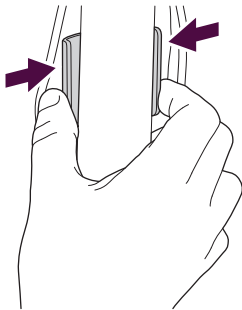

16.1

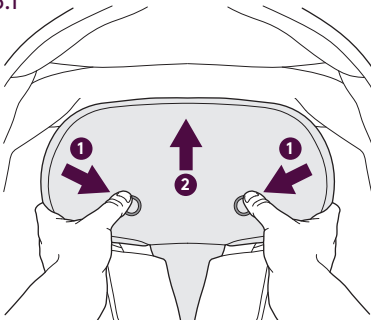

16.2

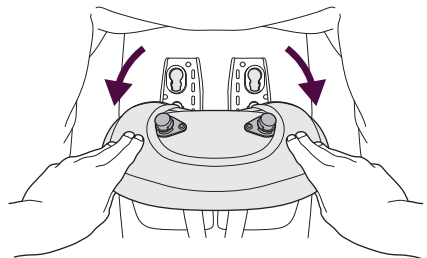

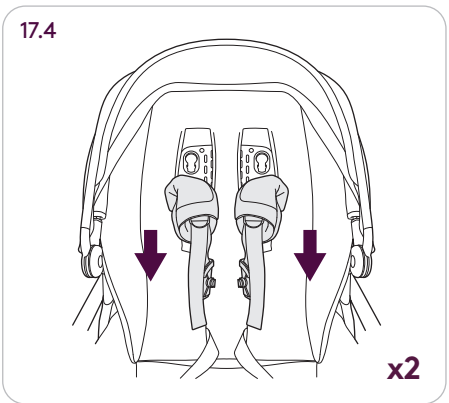
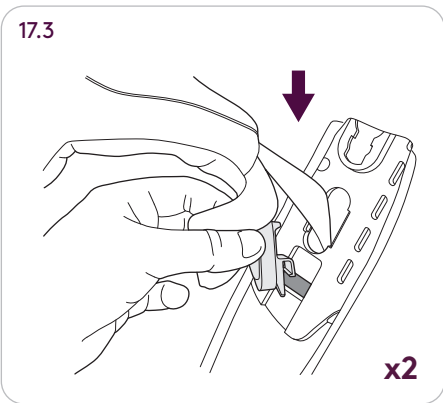
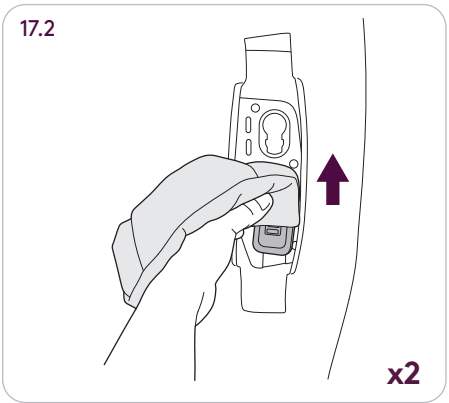
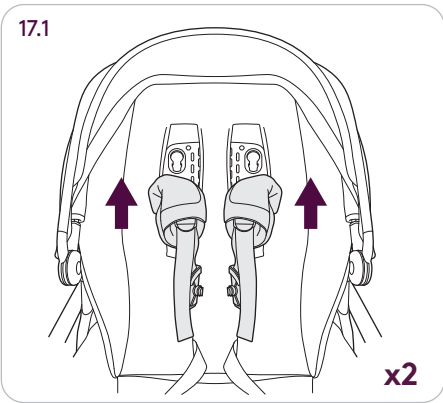
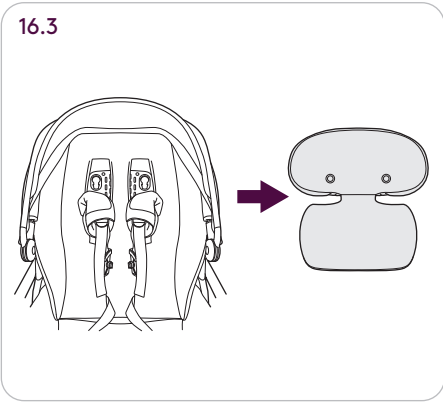

18.1

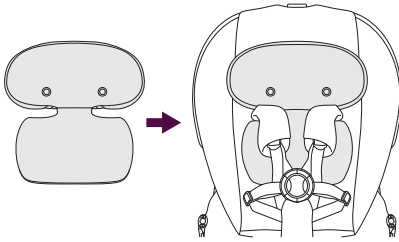

18.2

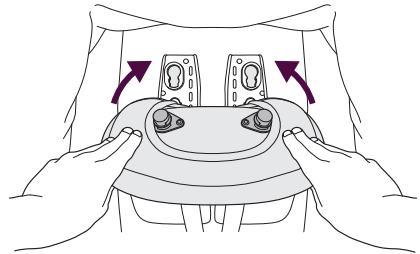

18.3

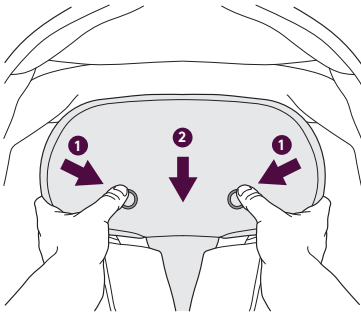

19.1

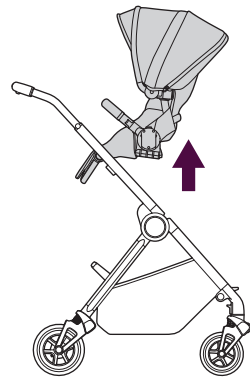
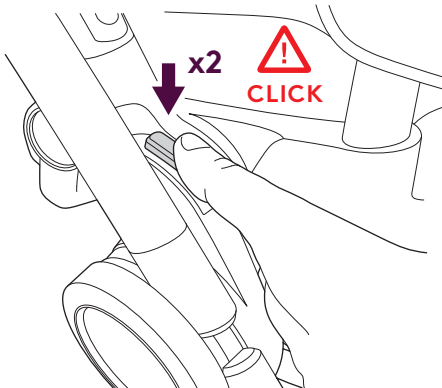

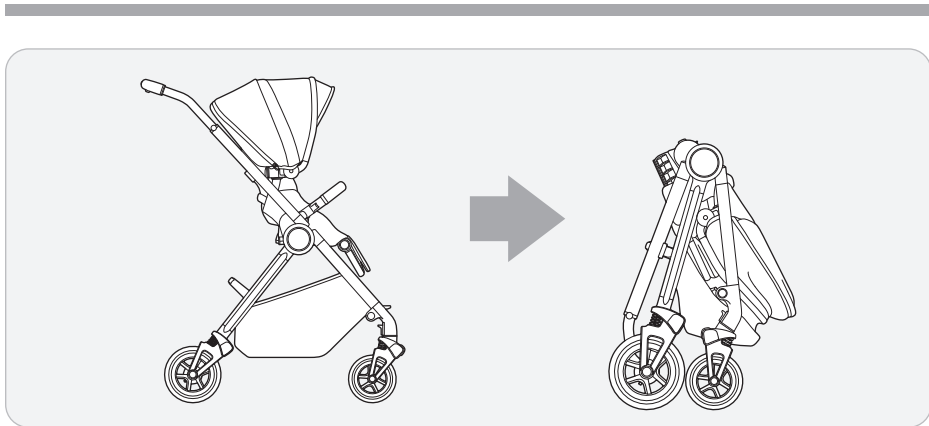
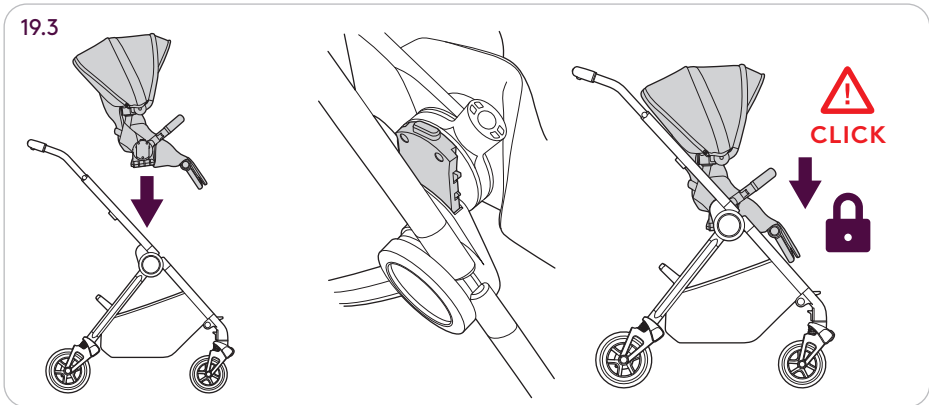
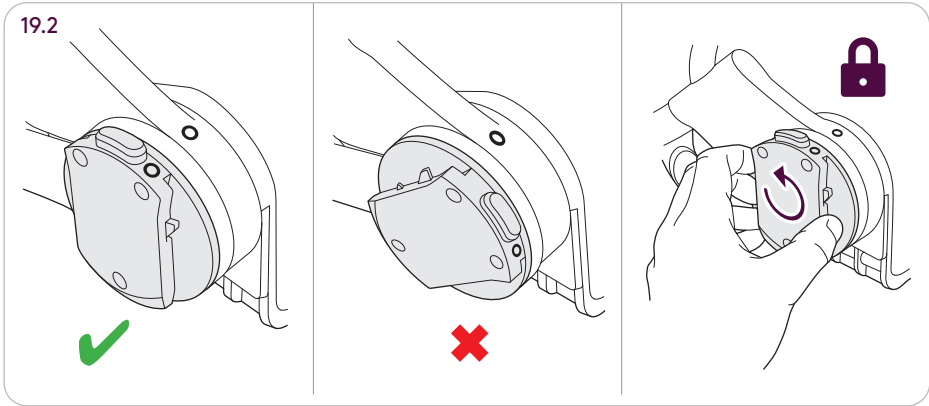

20.1

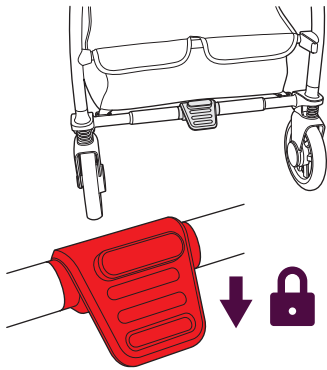

20.2

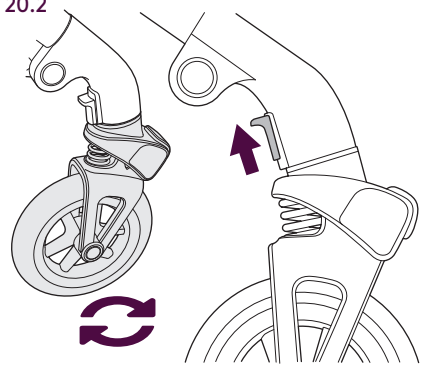

20.3

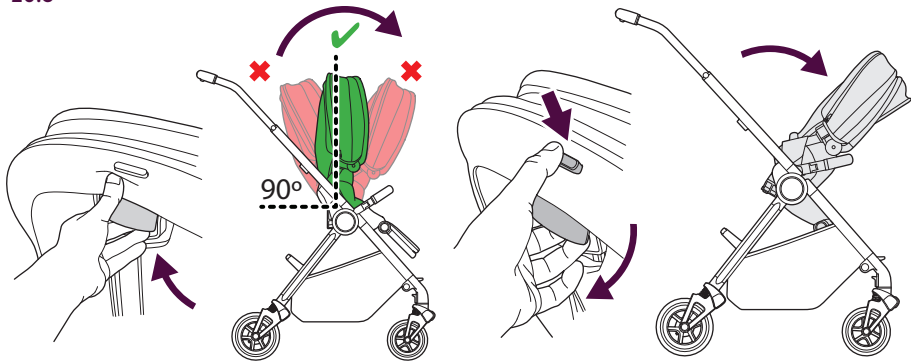

20.4

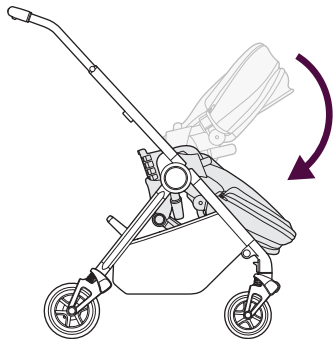

21.1

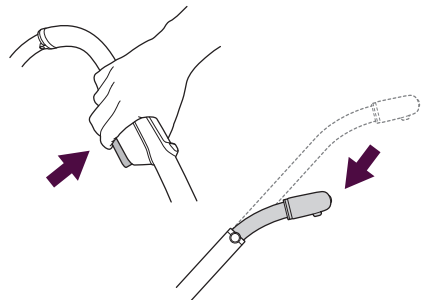

21.2

1

+

2

+

3

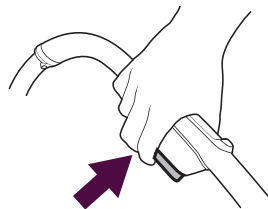
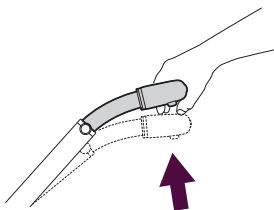
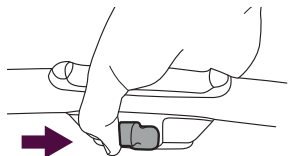

21.3

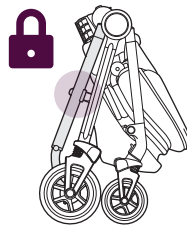
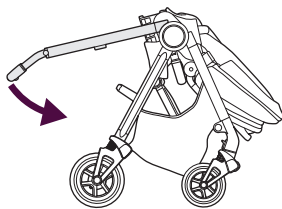
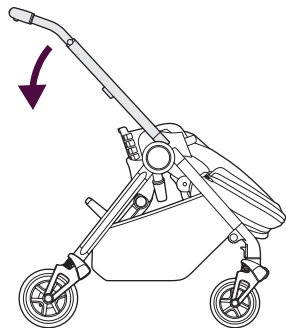

---

## ENG

**These instructions are important.**

Read these instructions before use and keep them for future reference. Your child's safety may be affected if you do not follow these instructions.

Your Dune travel system is a high quality Silver Cross product. It meets current safety standards and care and regular light maintenance will ensure its long service.

This travel system is suitable from birth up to 20lbs or 6 months old, whichever comes first with the bassinet; and from birth up to 55lbs or 4 years whichever comes first with the pushchair seat.

If somebody unfamiliar is using your Dune travel system, always ensure that they read these instructions carefully so that they understand how the product works best.

The Dune travel system is designed and tested to be used with the Dune Pushchair Seat, Compact Folding Bassinet (sold separately,) First-Bed Folding Bassinet (sold separately.)

### **SAFETY NOTES:**

The Dune travel system complies with ASTM F833-21

If you have any problems with the pushchair, please contact your Silver Cross retailer who will take appropriate action.

## **WARNINGS**

**NEVER LEAVE YOUR CHILD UNATTENDED**  
**FAILURE TO FOLLOW THESE WARNINGS AND THE INSTRUCTIONS COULD RESULT IN SERIOUS INJURY OR DEATH**  
**AVOID SERIOUS INJURY FROM FALLING OR SLIDING OUT.**  
**ALWAYS USE SEAT HARNESS.**  
**CHILD MAY SLIP INTO LEG OPENINGS AND STRANGLE.**  
**NEVER USE IN RECLINED CARRIAGE POSITIONS WITHOUT ATTACHING FOOT END BARRIER.**  
**DO NOT OVERLOAD THIS PRODUCT. FAILURE TO DO SO MAY CAUSE A HAZARDOUS UNSTABLE CONDITION TO EXIST**  
**THE SAFETY OF YOUR CHILD IS YOUR RESPONSIBILITY.**  
**ALWAYS USE THE RESTRAINT SYSTEM.**  
**THIS PRODUCT IS NOT SUITABLE FOR RUNNING OR SKATING.**  
**ALWAYS APPLY THE PARKING BRAKE WHEN PLACING AND REMOVING THE CHILD.**  
**ENSURE THAT ALL THE LOCKING DEVICES ARE ENGAGED BEFORE USE.**  
**TO AVOID INJURY, ENSURE THAT THE CHILD IS KEPT AWAY WHEN FOLDING AND UNFOLDING THIS PRODUCT.**  
**DO NOT LET THE CHILD PLAY WITH THIS PRODUCT.**  
**CHECK THAT THE BASSINET, SEAT UNIT OR CAR SEAT ATTACHMENT DEVICES ARE CORRECTLY ENGAGED BEFORE USE.**

---



**DO NOT CARRY MORE THAN ONE CHILD IN THIS PUSHCHAIR.**

**MAXIMUM CAPACITY FOR BASKET: 20LBS.**

**MAXIMUM CAPACITY FOR CUP HOLDER: 12OZ (SOLD SEPARATELY).**

**DO NOT LIFT A SEAT VIA THE BUMPER BAR WHILST A CHILD IS IN PLACE. THE BUMPER BAR IS NOT A CARRY HANDLE.**

**ALWAYS ENSURE THE BUMPER BAR IS ATTACHED WHEN YOUR CHILD IS IN THE PUSHCHAIR SEAT.**

**PLEASE ENSURE FOLDING MECHANISMS ARE KEPT CLEAR TO AVOID POSSIBLE FINGER ENTRAPMENTS OR INJURIES TO PARTS OF THE BODY.**

**ANY LOAD ATTACHED TO THE HANDLE AND/OR BACKREST AND/OR SIDES OF THE VEHICLE WILL AFFECT STABILITY OF THE VEHICLE.**

**ONLY REPLACEMENT PARTS AND ACCESSORIES APPROVED BY SILVER CROSS SHOULD BE USED.**

**ALWAYS USE THE MOST RECLINED POSITION FOR A NEWBORN BABY.**

**WHEN A CAR SEAT IS USED, THE HANDLE HEIGHT MUST BE IN EITHER OF THE HIGHEST 2 POSITIONS AND AT LEAST ONE ● MUST BE VISIBLE WHEN THE HANDLE IS AT THE CORRECT HEIGHT.**

#### **CARE AND MAINTENANCE:**

Hardware - Always check your pushchair for signs of wear. Regularly lubricate all moving parts. Check for freedom of movement of all locking devices. Polish metal work with a clean, dry cloth.

Dirt and dust within moving mechanisms may be rinsed away with clean water. Do not soak or submerge.

Fabric items - Please refer to the washcare instructions on each individual item's washcare label.

Seat Unit - To clean, sponge area with warm soapy water. Rinse well with clean water to avoid staining. Allow to dry naturally, away from direct heat and strong sunlight.

Never machine wash, tumble dry, iron or bleach any of the fabric items or seat unit. A certain degree of fading may occur over time through everyday use.

---

## **SPA**

**Estas instrucciones son importantes.**

La silla Dune es un producto de gran calidad de Silver Cross. Cumple la normativa ASTM F833-21 y, si la utiliza adecuadamente y realiza un buen mantenimiento, le proporcionará un servicio excelente. No obstante, si tiene algún problema con su silla, póngase en contacto con el punto de venta de Silver Cross donde la adquirió para que se encargue de tomar las debidas medidas.

Esta silla de paseo es adecuada desde el nacimiento hasta 20lbs con el capazo y a partir de 6 meses, hasta 55lbs o 4 años, lo que venga primero, usando la unidad de asiento.

El sistema de viaje Dune ha sido diseñado y probado para utilizarse con la silla de paseo Dune, el

Capazo compacto plegable (se vende por separado), el First-Bed Folding Bassinet (se vende por separado).

## **ADVERTENCIA**

**NUNCA DEJE AL NIÑO DESATENDIDO.**

**EL NO SEGUIR ESTAS ADVERTENCIAS E INSTRUCCIONES PODRÍA RESULTAR EN LESIONES GRAVES O LA MUERTE. EL NIÑO PUEDE DESLIZARSE HACIA LAS ABERTURAS PARA LAS PIERNAS Y ESTRANGULARSE. NUNCA LO USE EN POSICIÓN RECLINADA SIN USAR EL ARNÉS PROVISTO.**

**IMPORTANTE – LEER DETENIDAMENTE Y MANTENERLAS PARA FUTURAS CONSULTAS**

**NO DEJE AL NIÑO SIN VIGILANCIA EN NINGÚN MOMENTO.**

**PARA EVITAR LESIONES, ASEGÚRESE DE QUE EL NIÑO SE MANTENGA ALEJADO AL PLEGAR Y DESPLEGAR ESTE PRODUCTO.**

**ASEGÚRESE DE QUE TODOS LOS DISPOSITIVOS DE INMOVILIZACIÓN ESTÉN ACCIONADOS ANTES DE SU USO.**

**NO TRANSPORTE A MÁS DE UN NIÑO EN ESTA SILLA.**

**ESTE PRODUCTO NO ES APTO PARA CORRER NI PARA PATINAR.**

**ASEGÚRESE DE QUE LOS FRENOS ESTÉN ACCIONADOS AL COLOCAR Y RETIRAR AL NIÑO.**

**COMPRUEBE QUE LOS DISPOSITIVOS DE SUJECIÓN (YA SEAN LOS DEL CHASIS, EL ASIENTO O LA SILLA DEL COCHE) ESTÉN ACCIONADOS CORRECTAMENTE ANTES DE SU USO.**

**NO DEJE QUE EL NIÑO JUEGUE CON ESTE PRODUCTO.**

**ASEGÚRESE DE QUE LA BARRA PROTECTORA ESTÉ SIEMPRE SUJETA CUANDO EL NIÑO ESTÉ EN EL ASIENTO.**

**UTILICE SIEMPRE EL SISTEMA DE RETENCIÓN SUMINISTRADO.**

**UTILICE SIEMPRE LA POSICIÓN MÁS RECLINADA PARA UN BEBÉ RECIÉN NACIDO**

**LOS PESOS QUE SE CUELGUEN DEL MANILLAR, RESPALDO O LATERALES DEL VEHÍCULO, AFECTARÁN A SU ESTABILIDAD.**

**COMPRUEBE QUE LOS MECANISMOS DE PLEGADO ESTÉN DESPEJADOS PARA EVITAR EL POSIBLE ATRAPAMIENTO DE DEDOS Y LESIONES EN OTRAS PARTES DEL CUERPO.**

**NO SUBA EL ASIENTO CON SUJETÁNDOLO POR LA BARRA DE SEGURIDAD CON EL NIÑO SENTADO. LA BARRA DE SEGURIDAD NO ES UN ASA DE TRANSPORTE.**

**SOLO DEBEN UTILIZARSE PIEZAS DE RECAMBIO SUMINISTRADAS O RECOMENDADAS POR SILVER CROSS.**

**CAPACIDAD MÁXIMA DE LA CESTA: 11LBS.**

**CAPACIDAD MÁXIMA DEL PORTAVASOS: 12OZ. SE VENDE POR SEPARADO**

**CUANDO SE UTILICE UN SILLA DE SEGURIDAD, LA ALTURA DEL MANGO DEBE ESTAR EN CUALQUIERA DE LAS 2 POSICIONES MÁS ALTAS Y AL MENOS UNA ● DEBE ESTAR VISIBLE CUANDO EL MANGO ESTÁ A LA ALTURA CORRECTA.**

---

## CUIDADO Y MANTENIMIENTO

Chasis: Compruebe siempre la silla por si hubiera indicios de desgaste. Lubrique periódicamente todas las partes móviles. Compruebe que haya total libertad de movimiento en todos los dispositivos de bloqueo.

Pule el metal con un paño limpio y seco.

La suciedad y el polvo dentro de los mecanismos móviles pueden enjuagarse con agua limpia. No la moje ni sumerja.

Componentes de tela: Consulte las instrucciones de lavado en cada etiqueta individual.

Asiento: Para limpiarlo, pase una esponja por la zona con agua templada con jabón. Aclare bien con agua limpia para evitar manchas. Deje secar al aire, lejos del calor directo y de la luz solar fuerte.

Nunca lave a máquina, seque en secadora, planche o blanquee ninguno de los componentes de tela o el asiento.

Es posible que pierdan algo de color con el uso diario.

The logo for Silver Cross, featuring the brand name in a stylized, cursive script.

### USA

Silver Cross North America, Royal Baby  
Distributors Inc. 2901 Stirling Rd,  
Suite 207, Fort Lauderdale FL 33312

Silver Cross®



The mark of  
responsible forestry

[silvercrossus.com](http://silvercrossus.com)