

EST.  
1877

# Jet

*Silver Cross*<sup>®</sup>

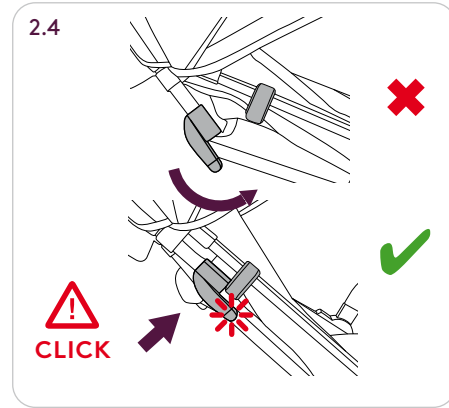

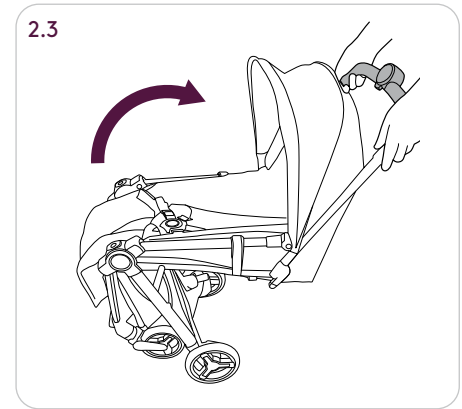
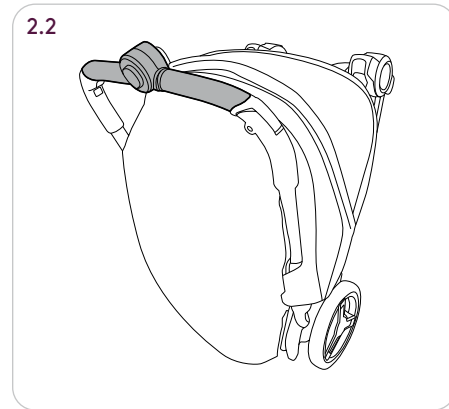
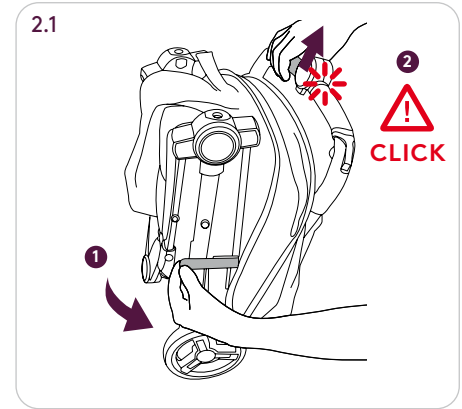
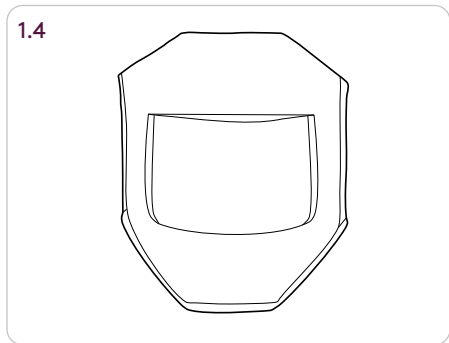
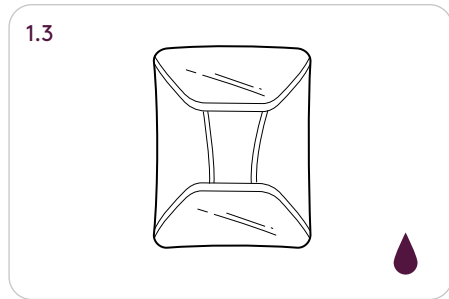
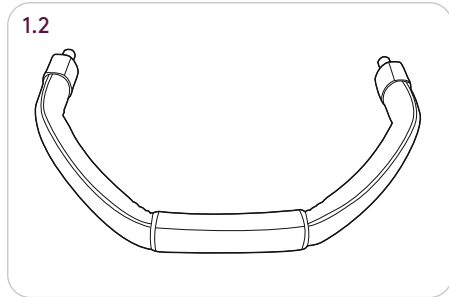
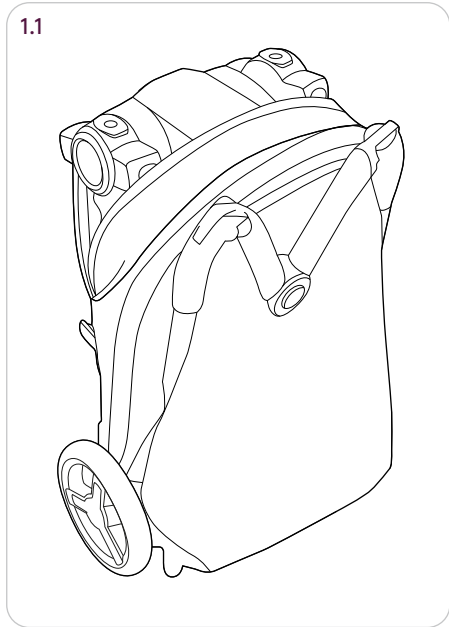
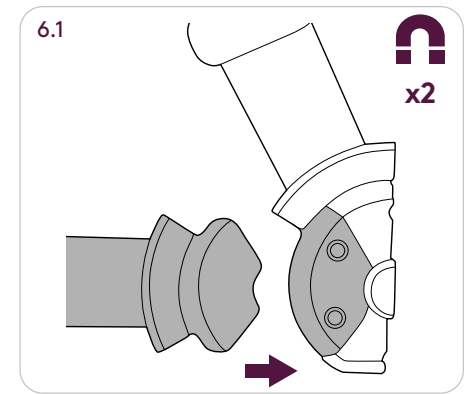
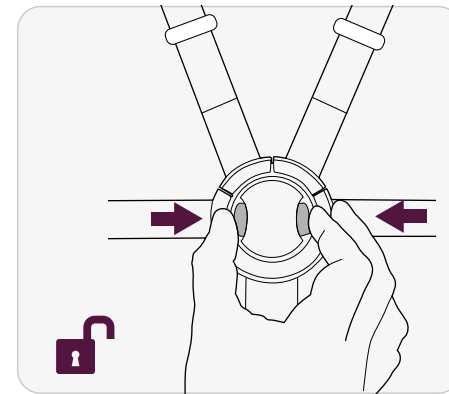
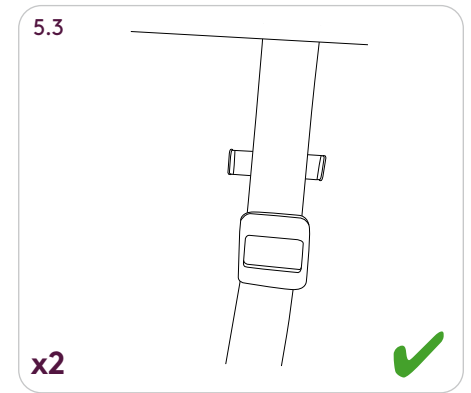
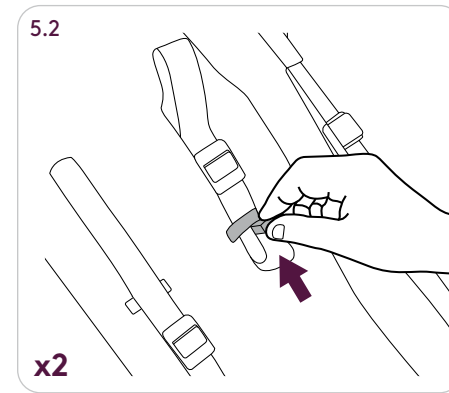
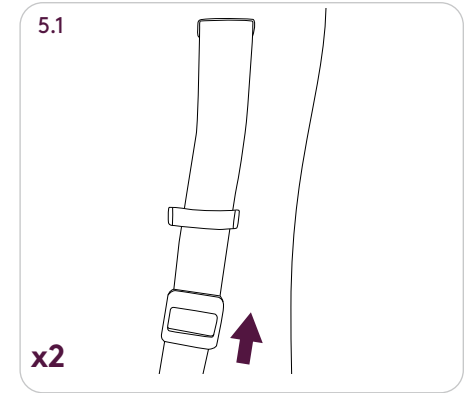
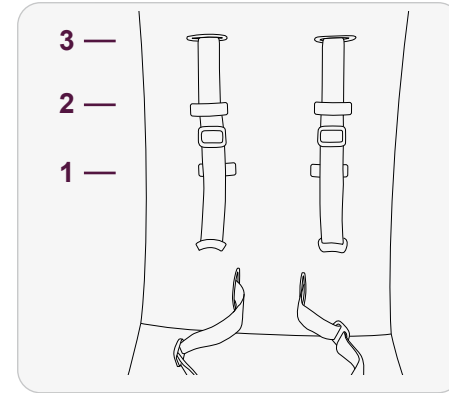
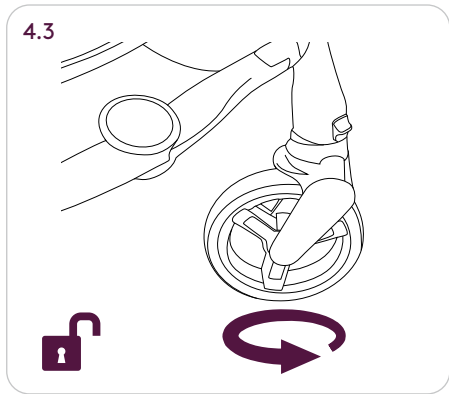
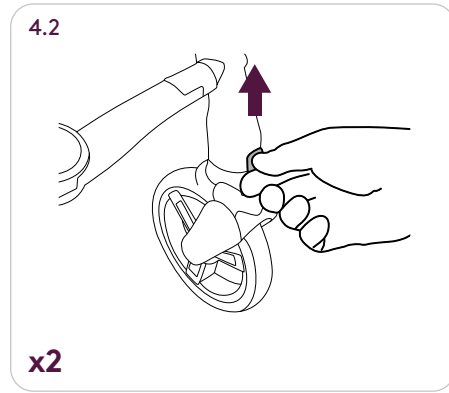
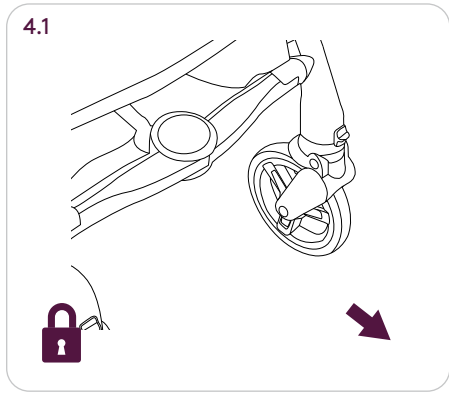
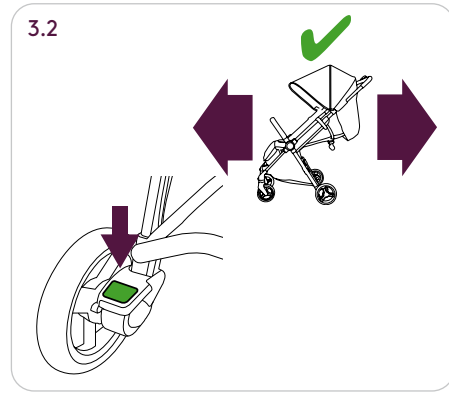
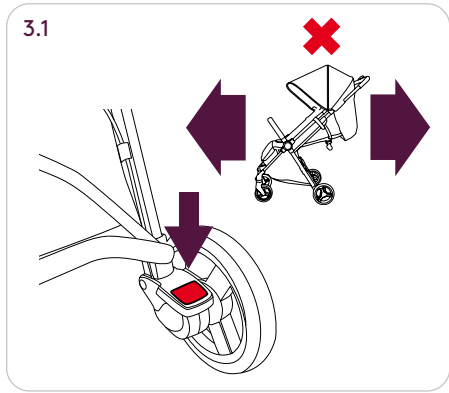

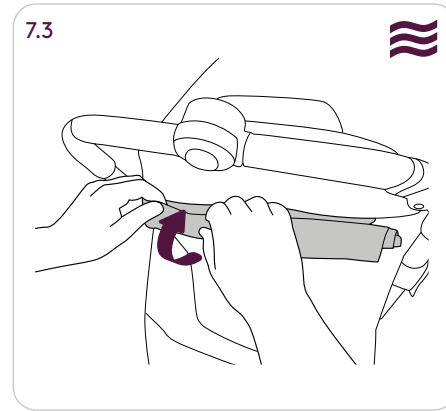
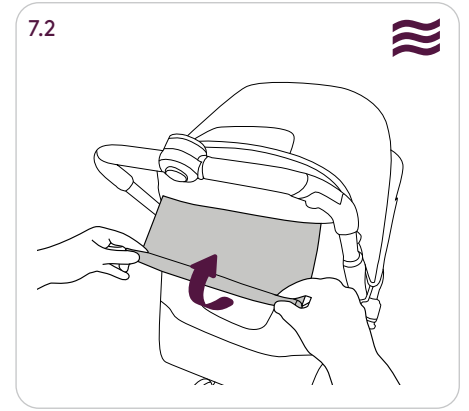
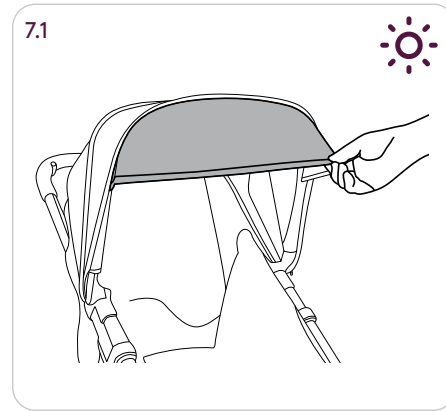
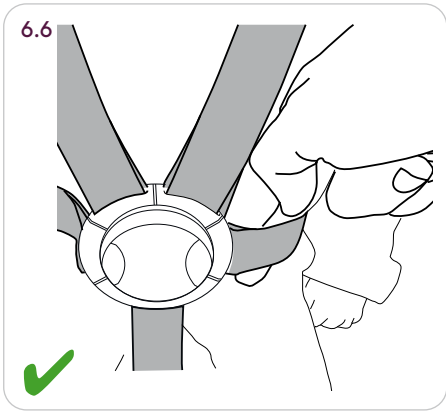
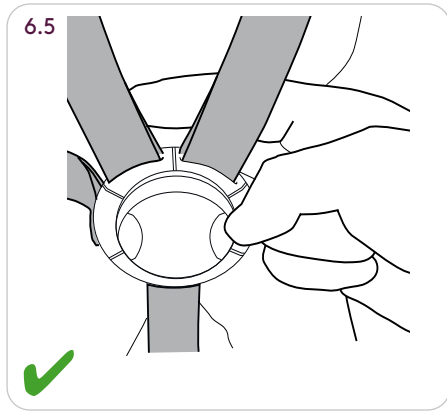
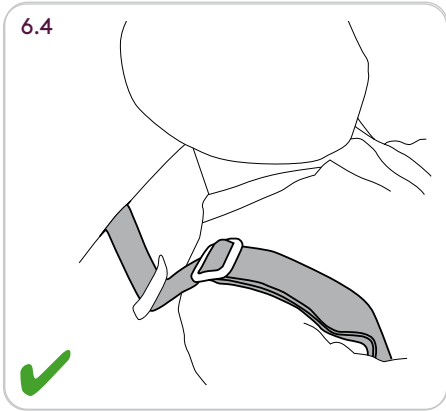
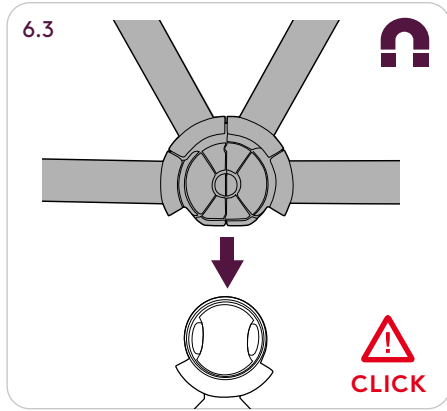
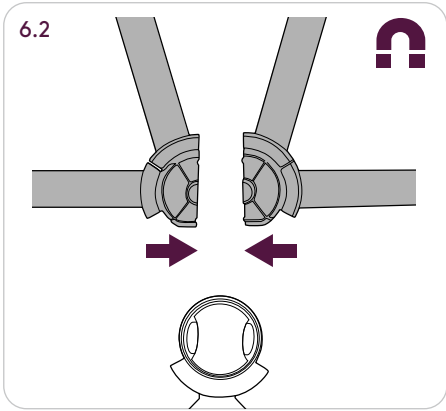

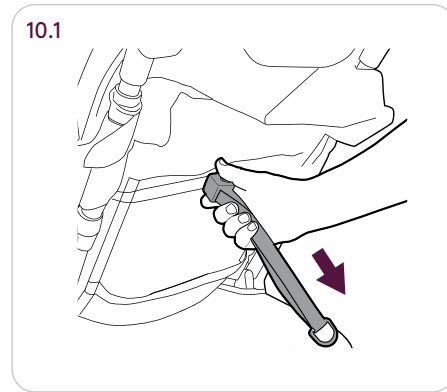
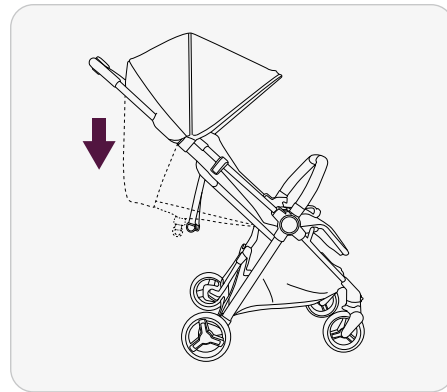
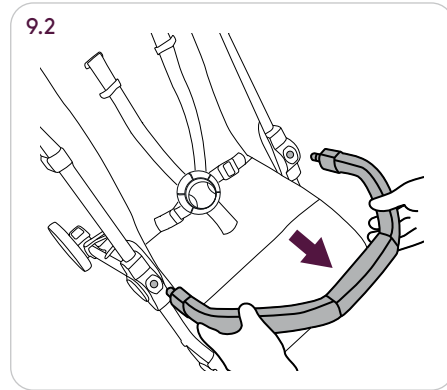
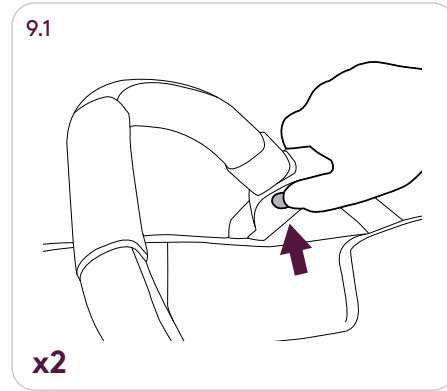
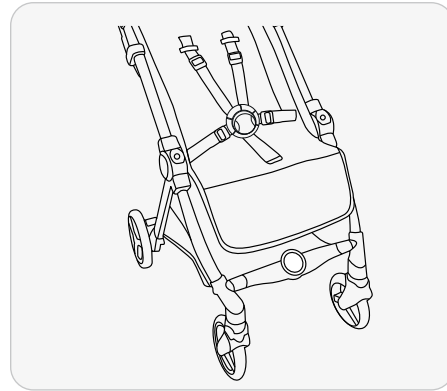
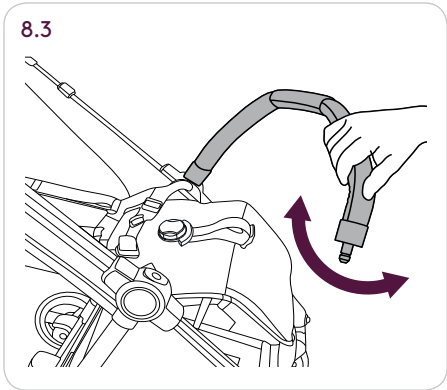
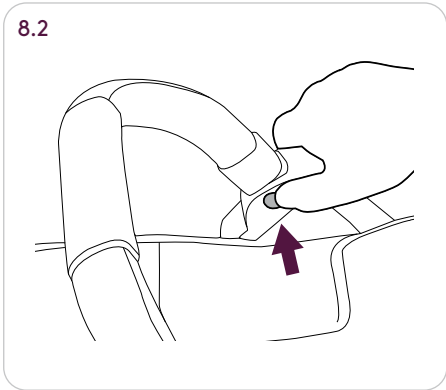
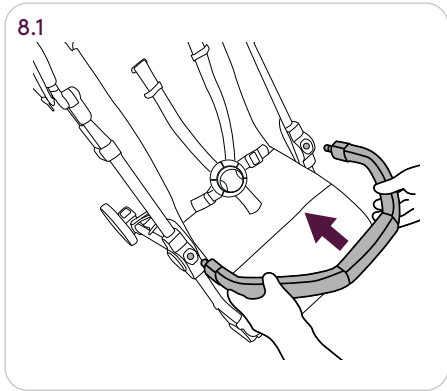
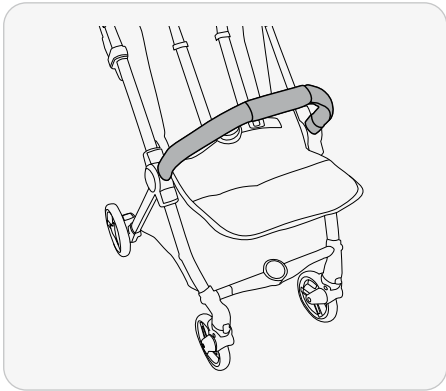

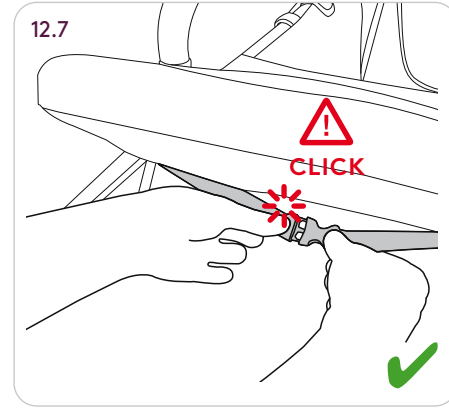
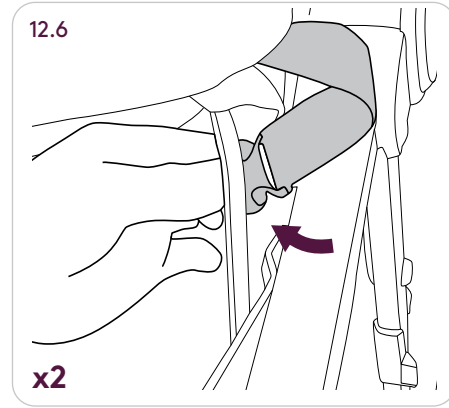
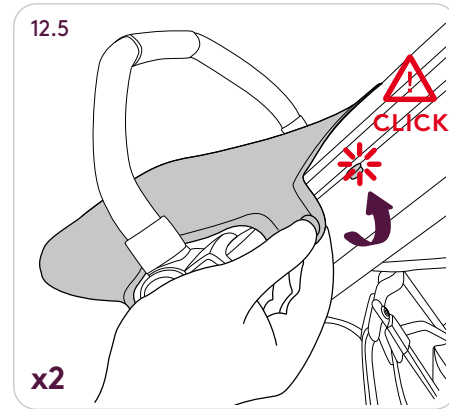
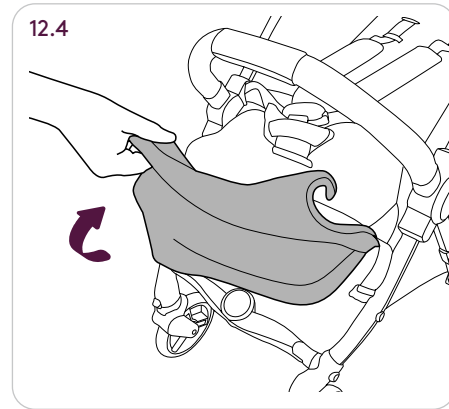
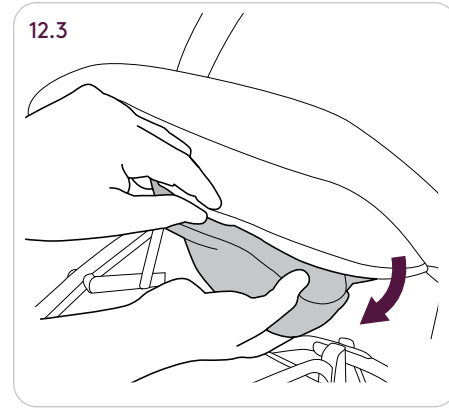
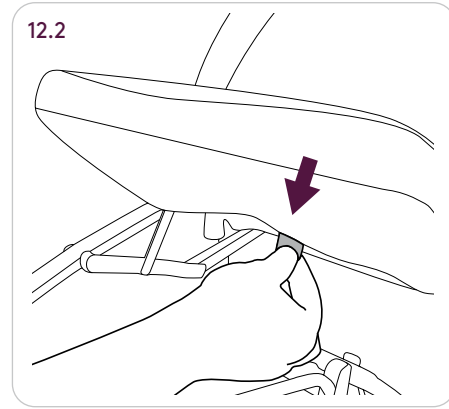
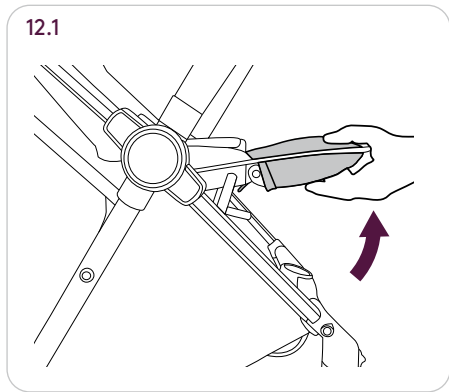
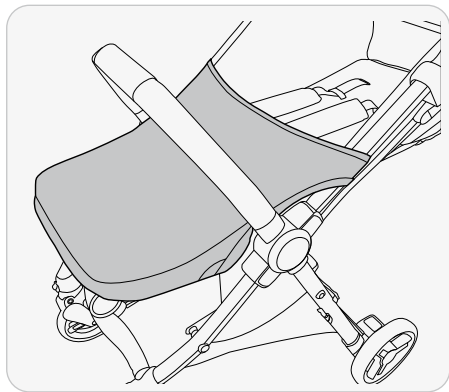
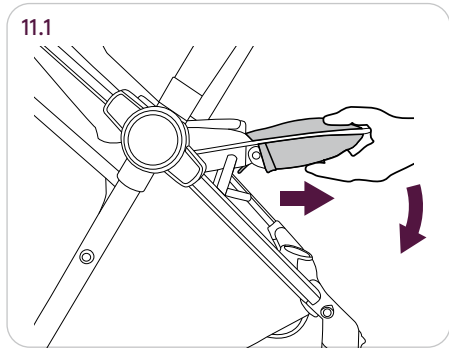
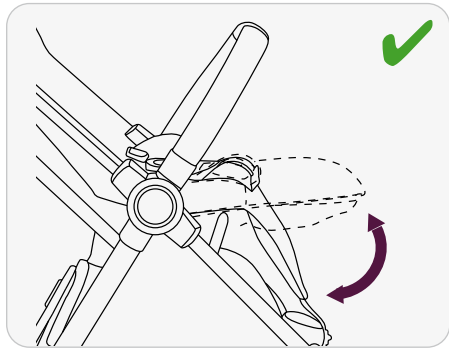
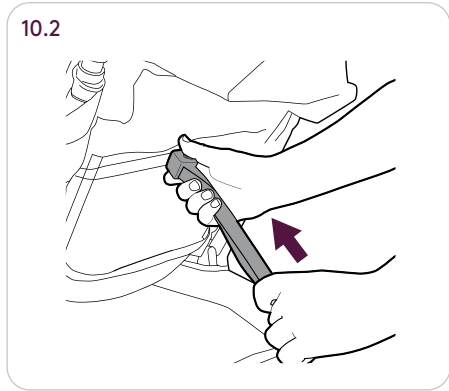
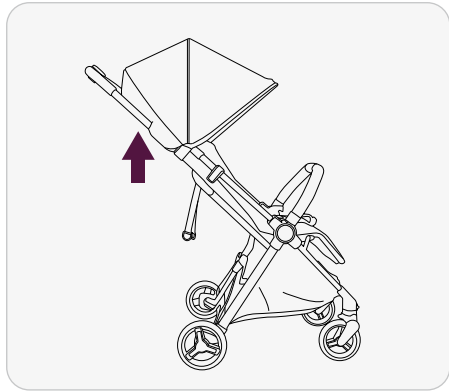

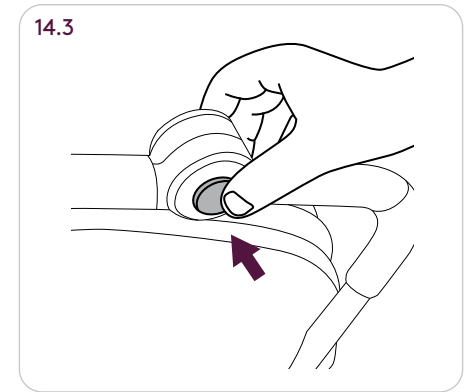
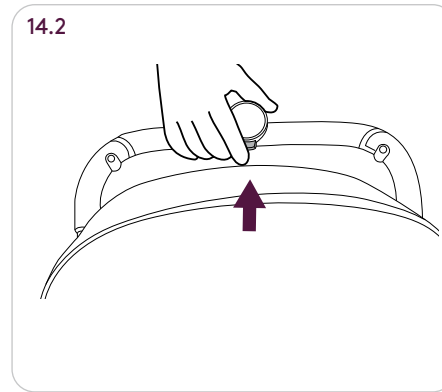
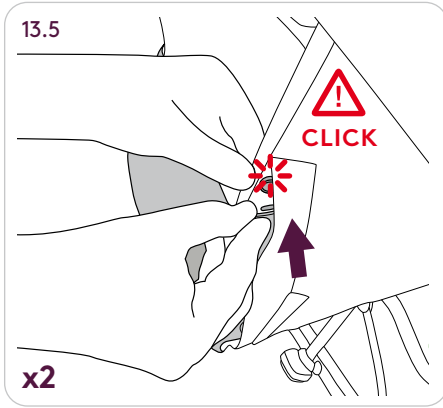
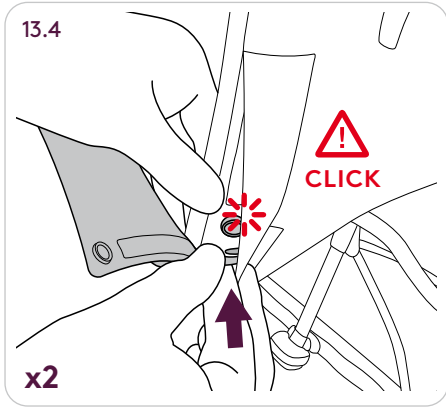
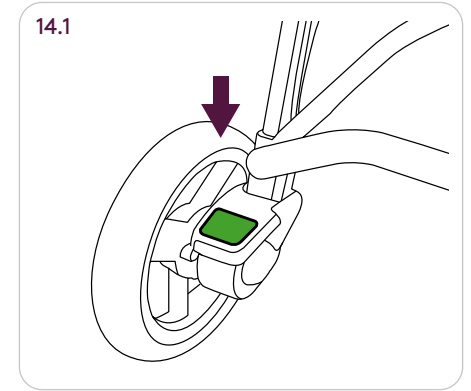
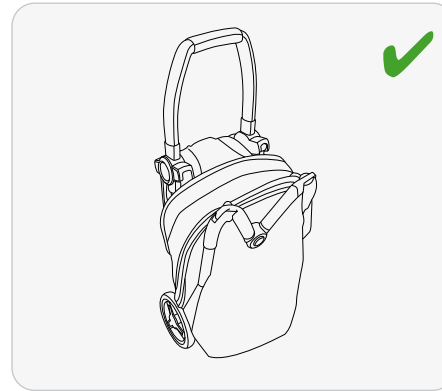
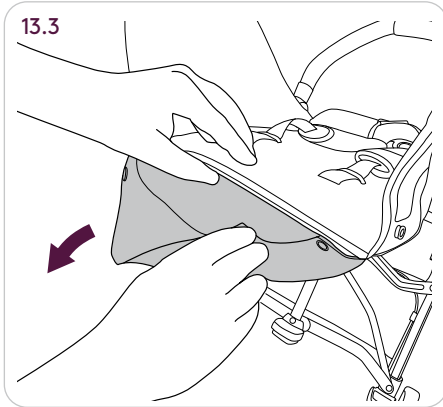
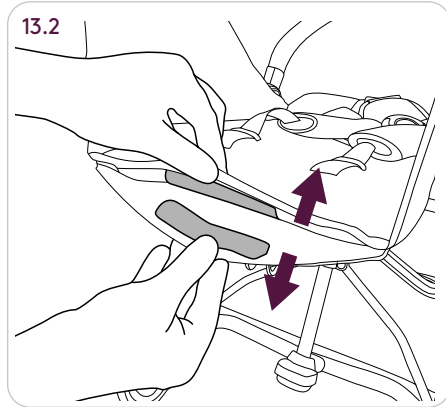
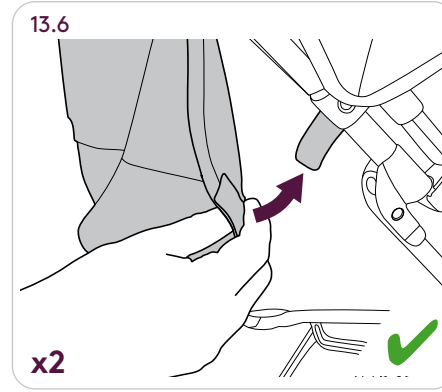
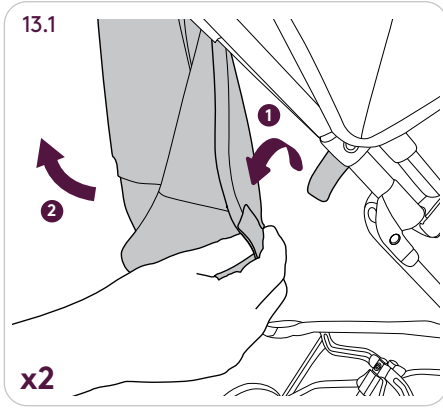
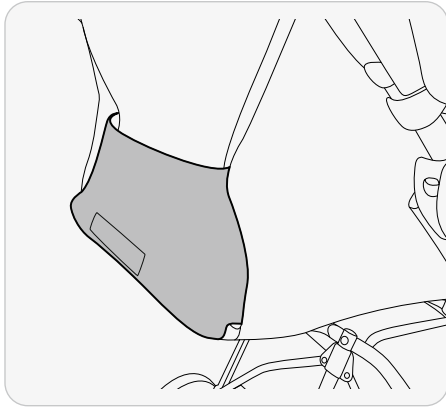

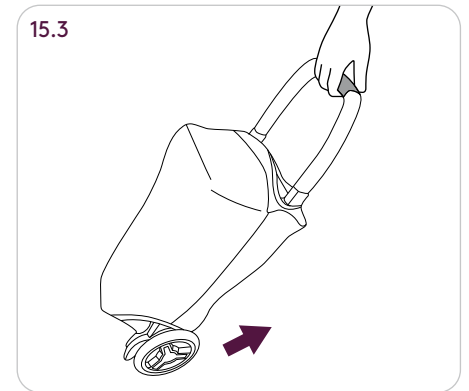
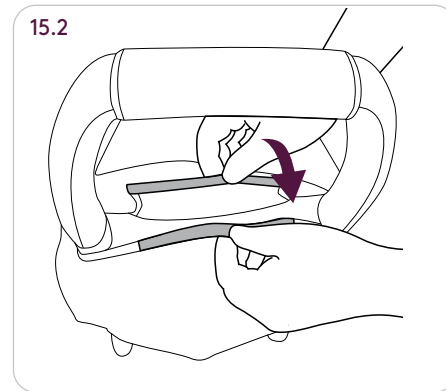
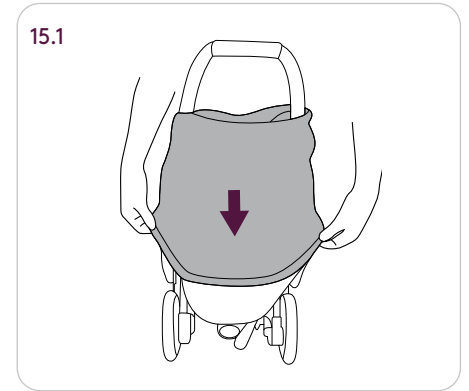
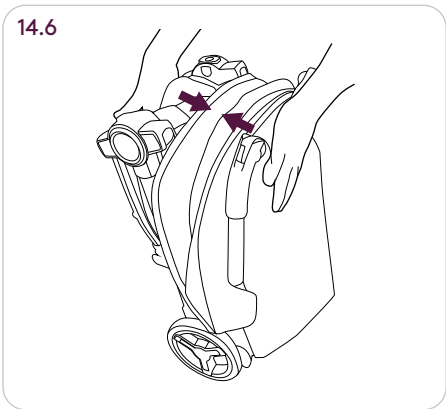
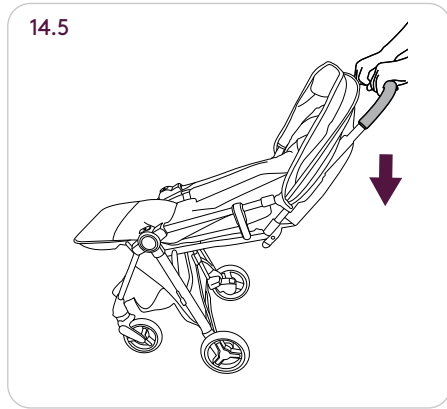
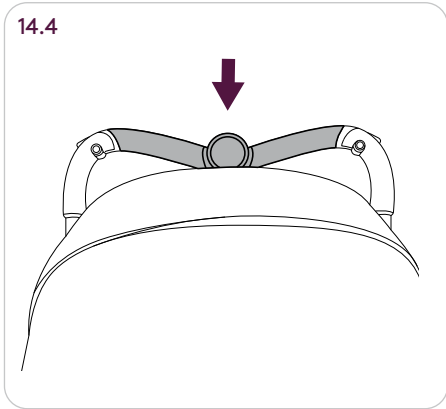



### These instructions are important.

Read these instructions before use and keep them for future reference. Your child's safety may be affected if you do not follow these instructions.

Your Jet stroller is a high quality Silver Cross product. It meets current safety standards and care and regular light maintenance will ensure its long service.

This stroller is suitable from birth up to 55 lb.

If somebody unfamiliar is using your Jet stroller, always ensure that they read these instructions carefully so that they understand how the product works best.

The Jet stroll is designed and tested to be used with a range of car seats. For a list of compatible car seats, please visit our website:

### Safety Notes

The Jet stroller is a high quality Silver Cross product. It complies with ASTM F833-21 and with correct use and maintenance will give good service. If, however, you should have any problems with the stroller, please contact your Silver Cross retailer who will take appropriate action.

[www.silvercrossus.com](http://www.silvercrossus.com)

**⚠️ WARNING**  
READ ALL INSTRUCTIONS BEFORE USE.

**⚠️ WARNING**  
ALWAYS APPLY THE PARKING BRAKE WHEN YOU ARE STANDING STILL.

**⚠️ WARNING**  
ALWAYS APPLY THE PARKING BRAKE WHEN PLACING AND REMOVING THE CHILD.

**⚠️ WARNING**  
FAILURE TO FOLLOW THIS WARNINGS AND INSTRUCTIONS COULD RESULT IN SERIOUS INJURY OR DEATH.

MAXIMUM CAPACITY FOR BASKET: 2.2LB.

CHECK THE WHEELS ARE SECURE BY GENTLY PULLING THE WHEELS AWAY FROM THE FRAME.

ALWAYS CHECK THAT THE PARKING BRAKE IS FULLY ENGAGED BY GENTLY MOVING THE FRAME BACKWARDS & FORWARDS.

**⚠️ WARNING**  
BEFORE MAKING ANY ADJUSTMENTS TO THE FRAME, ENSURE THE PARKING BRAKE IS ENGAGED.

**⚠️ WARNING**  
THE BUMPER BAR MUST BE SECURELY CONNECTED AT BOTH SIDES AT ALL TIMES WHEN IN USE. THE SAFETY OF YOUR CHILD IS YOUR RESPONSIBILITY.

**⚠️ WARNING**  
DO NOT LIFT THE STROLLER VIA THE BUMPER BAR WHILST A CHILD IS IN PLACE. THE BUMPER BAR IS NOT A CARRY HANDLE.  
ALWAYS USE THE CROTCH STRAP IN COMBINATION WITH THE WAIST STRAP.

**⚠️ WARNING**  
WINTER/SUMMER CLOTHING CAN MAKE A DIFFERENCE TO THE SIZE OF YOUR CHILD.

**⚠️ WARNING**  
BEFORE YOU USE THE STROLLER THE HARNESS MUST BE ADJUSTED TO SUIT THE SIZE OF YOUR CHILD. ALWAYS USE THE HARNESS.

**⚠️ WARNING**  
DUE CARE SHOULD BE TAKEN WHEN FOLDING AND UNFOLDING THE FRAME. PLEASE ENSURE FOLDING MECHANISMS ARE KEPT CLEAR TO AVOID POSSIBLE FINGER ENTRAPMENTS OR INJURIES TO PARTS OF THE BODY.

**⚠️ WARNING**  
TO AVOID POSSIBLE INJURY OR DAMAGE, ALWAYS ENSURE THE FOLD LOCK HAS BEEN ENGAGED BEFORE LIFTING AND CARRYING THE FRAME.

CARRY THE FOLDED FRAME USING THE BUMPER BAR.

**⚠️ WARNING**  
READ ALL INSTRUCTIONS BEFORE USE.

**⚠️ WARNING**  
NEVER LEAVE YOUR CHILD UNATTENDED.

**⚠️ WARNING**  
TO AVOID INJURY, ENSURE THAT YOUR CHILD IS KEPT AWAY WHEN FOLDING AND UNFOLDING THIS PRODUCT.

**⚠️ WARNING**  
DO NOT LET YOUR CHILD PLAY WITH THIS PRODUCT.

**⚠️ WARNING**  
AVOID SERIOUS INJURY FROM FALLING OR SLIDING OUT. ALWAYS USE THE RESTRAINT SYSTEM.

**⚠️ WARNING**

DO NOT CARRY MORE THAN ONE CHILDREN IN THIS PUSHCHAIR.

**⚠️ WARNING**

THIS PRODUCT IS NOT SUITABLE FOR RUNNING OR SKATING.

**⚠️ WARNING**

CHILD MAY SLIP INTO LEG OPENINGS AND STRANGLE. NEVER USE IN RECLINED POSITION WITHOUT ATTACHING FOOT END BARRIER.

**⚠️ WARNING**

DO NOT OVERLOAD THIS PRODUCT. FAILURE TO DO SO MAY CAUSE A HAZARDOUS UNSTABLE CONDITION TO EXIST.

**⚠️ WARNING**

ANY LOAD ATTACHED TO THE HANDLE AND/OR BACKREST AND/OR SIDES OF THE VEHICLE WILL AFFECT STABILITY OF THE VEHICLE. A BABY'S SAFETY IS YOUR RESPONSIBILITY.

**Care and maintenance**

Chassis - Always check your stroller for signs of wear. Regularly lubricate all moving parts. Check for freedom of movement of all locking devices. Polish metal work with a clean, dry cloth.

Dirt and dust within moving mechanisms may be rinsed away with clean water. Do not soak or submerge.

Fabric items - Please refer to the washcare instructions on each individual item's washcare label.

Seat Unit - To clean, sponge area with warm soapy water. Rinse well with clean water to avoid staining. Allow to dry naturally, away from direct heat and strong sunlight.

Never machine wash, tumble dry, iron or bleach any of the fabric items or seat unit. A certain degree of fading may occur over time through everyday use.

Please read these instructions carefully before using your new Silver Cross product and keep for future reference.

[www.silvercrossus.com](http://www.silvercrossus.com)

**IMPORTANTE: GUARDE ESTAS INSTRUCCIONES PARA CONSULTARLAS POSTERIORMENTE**

Estas instrucciones son importantes.

Lea estas instrucciones antes del uso y guárdelas para consultarlas posteriormente. Puede poner en peligro la seguridad de su hijo si no sigue estas instrucciones.

Su silla de paseo Jet es un producto de alta calidad de Silver Cross. Cumple las normativas de seguridad actuales y, con un ligero cuidado y mantenimiento, asegurará una larga vida útil.

Este silla de paseo es adecuada desde el nacimiento hasta 55 lb.

Si alguien no familiarizado con el silla de paseo va a utilizar su Jet cochecito, asegúrese siempre de que haya leído atentamente estas instrucciones para que sepa cómo funciona mejor el producto.

El silla de paseo Jet está diseñado y probado para ser utilizado con una gama de asientos de automóvil. Para obtener una lista de asientos de automóvil compatibles, visite nuestro sitio web:

[www.silvercrossus.com](http://www.silvercrossus.com)

**Notas de seguridad**

La silla de paseo Jet es un producto de gran calidad de Silver Cross.

Cumple con la normativa ASTM F833-21 y, si la utiliza adecuadamente y realiza un buen mantenimiento, le proporcionará un servicio excelente. No obstante, si tiene algún problema con su producto, póngase en contacto con el minorista Silver Cross, quien se encargará apropiadamente del asunto.

**⚠️ ADVERTENCIA**

LEA TODAS LAS INSTRUCCIONES ANTES DE USARLO.

**⚠️ ADVERTENCIA**

PONGA SIEMPRE EL FRENO DE APARCAMIENTO CUANDO SE DETENGA.

**⚠️ ADVERTENCIA**

PONGA SIEMPRE EL FRENO DE APARCAMIENTO CUANDO COLOQUE O SAQUE AL NIÑO.

**⚠️ ADVERTENCIA**

EL NO SEGUIR ESTAS ADVERTENCIAS E INSTRUCCIONES PODRÍA RESULTAR EN LESIONES GRAVES O LA MUERTE.

CAPACIDAD MÁXIMA PARA CESTA: 2.2LB.

COMPRUEBE QUE LAS RUEDAS SON SEGURAS TIRANDO SUAVEMENTE DE ELLAS PARA SEPARARLAS DEL CHASIS.

COMPRUEBE SIEMPRE QUE EL FRENO DE APARCAMIENTO ESTÁ COMPLETAMENTE ENGRANADO MOVIENDO SUAVEMENTE EL CHASIS HACIA ATRÁS Y HACIA DELANTE.

**⚠️ ADVERTENCIA**

ANTES DE REALIZAR CUALQUIER AJUSTE EN EL CHASIS, ASEGÚRESE DE QUE EL FRENO DE APARCAMIENTO ESTÁ ENGRANADO.

**⚠️ ADVERTENCIA**

LA BARRA APOYA BRAZOS DEBE ESTAR ACOPLADA DE FORMA SEGURA EN LOS DOS LADOS SIEMPRE QUE SE UTILICE. USTED ES RESPONSABLE DE LA SEGURIDAD DE SU HIJO.

**⚠️ ADVERTENCIA**

NO LEVANTE LA SILLA DE PASEO POR LA BARRA APOYA BRAZOS CUANDO HAYA UN NIÑO COLOCADO EN SU INTERIOR. LA BARRA PARACHOQUES NO ES UN ASA DE TRANSPORTE.

UTILICE SIEMPRE LA CORREA DE ENTREPIERNA EN COMBINACIÓN CON LA CORREA DE CINTURA.

**⚠️ ADVERTENCIA**

LA ROPA DE INVIERNO O VERANO PUEDE MARCAR UNA DIFERENCIA EN EL TAMAÑO DE SU HIJO.

**⚠️ ADVERTENCIA**

ANTES DE UTILIZAR LA SILLA DE PASEO, EL ARNÉS DEBE ESTAR AJUSTADO AL TAMAÑO DE SU HIJO. UTILICE SIEMPRE EL ARNÉS.

**⚠️ ADVERTENCIA**

DEBERÍA TENER EL DEBIDO CUIDADO CUANDO PLIEGUE Y DESPLIEGUE EL CHASIS. ASEGÚRESE DE QUE EL MECANISMO DE PLEGADO SE MANTIENE DESPEJADO PARA EVITAR POSIBLES ENGANCHES DE LOS DEDOS O LESIONES EN PARTES DEL CUERPO.

**⚠️ ADVERTENCIA**

PARA EVITAR POSIBLES LESIONES O DAÑOS, ASEGÚRESE SIEMPRE DE QUE EL BLOQUEO DE PLEGADO ESTÉ ENGRANADO ANTES DE LEVANTAR Y TRANSPORTAR EL CHASIS.

TRANSPORTE EL CHASIS PLEGADO POR LA BARRA APOYA BRAZOS.

**⚠️ ADVERTENCIA**

NUNCA DEJE AL NIÑO DESATENDIDO.

**⚠️ ADVERTENCIA**

PARA EVITAR LESIONES, ASEGÚRESE DE QUE EL NIÑO NO ESTÉ CERCA CUANDO PLIEGUE Y DESPLIEGUE ESTE PRODUCTO.

**⚠️ ADVERTENCIA**

NO DEJE QUE SU NIÑO JUEGUE CON ESTE PRODUCTO.

**⚠️ ADVERTENCIA**

EVITE LESIONES GRAVES POR CAERSE O DESLIZARSE. USE SIEMPRE EL SISTEMA DE RETENCIÓN.

**⚠️ ADVERTENCIA**

NO LLEVE A MÁS DE UNO NIÑOS EN ESTE COHECITO.

**⚠️ ADVERTENCIA**

ESTE PRODUCTO NO ES ADECUADO PARA CORRER NI PATINAR.

**⚠️ ADVERTENCIA**

EL NIÑO PUEDE DESLIZARSE HACIA LAS ABERTURAS PARA LAS PIERNAS Y ESTRANGULARSE. NUNCA LO USE EN POSICIÓN RECLINADA SIN USAR LA FUNDA PARA LAS PIERNAS PROVISTO.

**⚠️ ADVERTENCIA**

NO SE DEBE PONER UNA CARGA EXCESIVA EN ESTE PRODUCTO. NO RESPETAR ESTA INDICACIÓN PUEDE RESULTAR EN UNA INESTABILIDAD PELIGROSA.

**⚠️ ADVERTENCIA**

LOS PESOS QUE SE CUELGUEN DEL MANILLAR Y/O RESPALDO Y/O LATERALES DEL VEHÍCULO AFECTARÁN A SU ESTABILIDAD. USTED ES RESPONSABLE DE LA SEGURIDAD DEL BEBÉ.

## Cuidado y mantenimiento

Chasis: Compruebe siempre la silla de paseo por si hubiera indicios de desgaste. Lubrique periódicamente todas las partes móviles. Compruebe que haya total libertad de movimiento en todos los dispositivos de bloqueo. Pula el metal con un paño limpio y seco.

La suciedad y el polvo dentro de los mecanismos móviles pueden enjuagarse con agua limpia. No la moje ni sumerja.

Componentes de tela: Consulte las instrucciones de lavado en cada etiqueta individual.

Asiento: Para limpiarlo, pase una esponja por la zona con agua templada con jabón. Aclare bien con agua limpia para evitar manchas. Deje secar al aire, lejos del calor directo y de la luz solar fuerte.

Nunca lave a máquina, seque en secadora, planche o blanquee ninguno de los componentes de tela o el asiento. Es posible que pierdan algo de color con el uso diario.

Lea detenidamente estas instrucciones antes de utilizar su nuevo producto Silver Cross y consérvelas para consultarlas en el futuro.

[www.silvercrossus.com](http://www.silvercrossus.com)

## Notes

Silver Cross®

Silver Cross North America, Royal Baby Distributors Inc. 2901 Stirling Rd,  
Suite 207, Fort Lauderdale FL 33312

[silvercrossus.com](http://silvercrossus.com)